



ASME B18.2.3.2M Hex Bolt

Leader-Fastener is a manufacturer and distributor of **ASME B18.2.3.2M Hex Bolt**. We have a complete line of service from having invested in production plants, export department and to having a quality control team and center to meet your requirements. We regard quality as the life of the company. We persist in good quality as the first policy and have established a set of quality control and inspection system according to the international standard. We have carried out ISO9001 Quality Guarantee System in every course of production, transportation and selling. We do hope we could be your partner in business by topping quality,

knight service and competitive price in the near future and be your friends as well.

Product Introduction of ASME B18.2.3.2M Hex Bolt

This Standard covers the complete dimensional and general data for metric formed hex screws recognized as American National Standard. Formed hex screws are cold formed products with fully upset (non-trimmed) heads. Formed hex screws are standard only in sizes M5 thru M24, with lengths up to 150 mm, or 10 times nominal screw size, whichever is shorter.

All dimensions in this Standard are given in millimeters (mm), and apply before coating, unless stated otherwise. Symbols specifying geometric characteristics are in accordance with ASME Y14.5M.

Hexagon bolts are a type of fastener consisting of a head and a screw (a cylinder with an external thread), and a nut is required to fasten two parts with a through hole. They are commonly used in residential and commercial mechanical and construction projects. Full thread size provides excellent grip strength. Some thread sizes help where shear resistance is important. Secure with corresponding nuts or use in threaded holes. A type of fastener consisting of a head and a screw (a cylinder with an external thread), which requires a nut to securely connect two parts with a through hole. Because bolts are also a type of railway accessories, railway accessories are an integral part of railway lines. The track referred to here includes rails, sleepers, connectors, ballast beds, anti-climbing equipment, rail supports and turnouts. As an overall engineering structure, the track is laid on the roadbed, which guides the operation of the train and directly bears the huge pressure and load of the rolling stock. Under the power of train operation, its components must have sufficient strength and stability to ensure the safe, stable and uninterrupted operation of the train at the specified maximum speed.

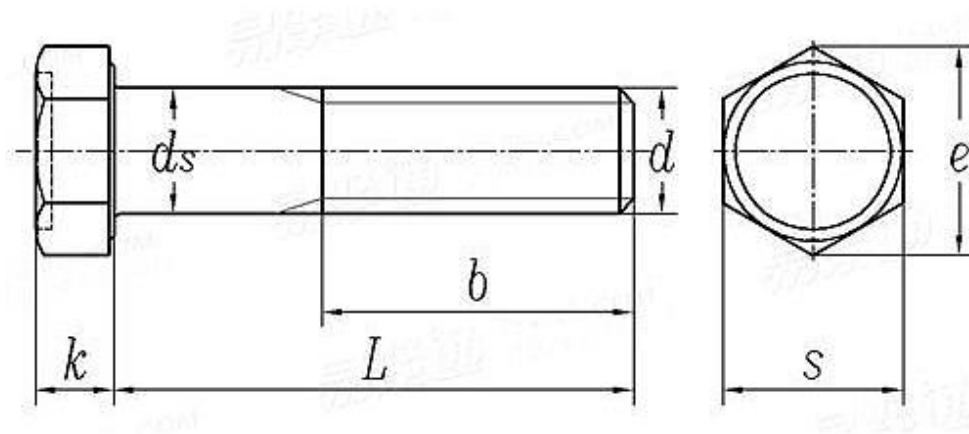
ASME B 18.2.3.2M - 2005 Metric hex head screws with depression

Nominal Diameter d		M5	M6	M8	M10	M10	M12	M14	M16	M20	M24
P	Pitch	0.8	1	1.25	1.5	1.5	1.75	2	2	2.5	3
ds	max	5	6	8	10	10	12	14	16	20	24
	min	4.82	5.82	7.78	9.78	9.78	11.73	13.73	15.73	19.67	23.67
s	max	8	10	13	15	16	18	21	24	30	36
	min	7.64	9.64	12.57	14.57	15.57	17.57	20.16	23.16	29.16	35
e	max	9.24	11.55	15.01	17.32	18.48	20.78	24.25	27.71	34.64	41.57
	min	8.56	10.8	14.08	16.32	17.43	19.68	22.58	25.94	32.66	39.2
k	max	3.65	4.15	5.5	6.63	6.63	7.76	9.09	10.32	12.88	15.44
	min	3.35	3.85	5.1	6.17	6.17	7.24	8.51	9.68	12.12	14.46
b	L≤125	16	18	22	26	26	30	34	38	46	54
	125<L≤200	22	24	28	32	32	36	40	44	52	60
	L>200	35	37	41	45	45	49	53	57	65	73